

2011

# Local Oscillator

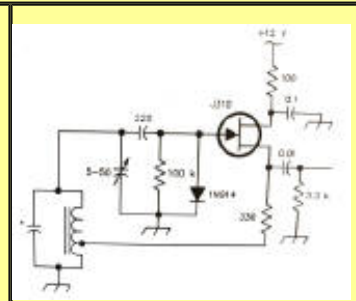

February

Mesilla Valley Radio Club

A [pdf file](#) of this issue is available. It should print fairly easily. If you do not have the free pdf file reader, go to <http://www.adobe.com>

## Coming Events

## Table of Contents

Date	Event	Time
M - F	6 m FM net 52.540	6:00AM
T, T	Informal Wal-Mart (E)	10:00AM
M, W, F	Informal Wal-Mart (W)	10:00AM
Mon	WTRA Swap net 146.88	8 PM
Wed	Net 146.64	6:45PM
Feb 1	Builders Group - Club House	7 PM
Feb 5	Breakfast - Club House	8 AM
Feb 5	Business meet - Club House	9 AM
Feb 15	Builders Group - Club House	7 PM
May 1	Bean Feed - Club House	
	for more events see <a href="http://www.n5bl.org/calendar">http://www.n5bl.org/calendar</a>	

COMING EVENTS  
 TABLE OF CONTENTS  
[FEBRUARY PROGRAM](#)  
[CONSTITUTION AND BYLAWS REVISION](#)  
[TECHNICIAN CLASS](#)  
[BUDGET](#)  
[DOCTOR](#)  
[MONTHLY BUSINESS MEETING](#)  
[MONTHLY BOARD MEETING](#)  
[UNCLASSIFIED](#)  
[BACK PAGE](#)



## Tech Class

**Southwest Antennas & Accessories**

more information at <http://swantenna.com>

The space below is used for acknowledgements and maintaining the site.  
Send comments, suggestions, and requests to [Alex. F. Burr](mailto:aburr@qzxservices.com) or send e-mail to [aburr@qzxservices.com](mailto:aburr@qzxservices.com).  
Technical assistance, net access, design, and maintenance provided by [qzxservices.com](http://qzxservices.com)

# THE ARTICLES FOR THIS MONTH

## FEBRUARY PROGRAM

KD5SSJ

Lew Maxwell from El Paso has been scheduled. He will talk about their new radio station out at the National Weather Service and how they will plan on using the WX5ELP station. It would not be more than 30 - 45 minutes if that long. The big thing is that we get participation when we do activate the station.

[Return to Table of Contents](#)

## CONSTITUTION AND BYLAWS REVISION

AD5LJ

The draft constitution that was reviewed at the January business meeting and the Board of Directors meeting has been revised and is again published for your review. All recommended changes have been incorporated. We will vote to approve the constitution at the February business meeting.

### MESILLA VALLEY RADIO CLUB

#### CONSTITUTION and BY LAWS

##### **Article I**

##### **Name, Purpose and Membership**

Section 1. The name of this organization shall be the MESILLA VALLEY RADIO CLUB, a non-profit organization incorporated under the laws of the State of New Mexico for charitable and educational purposes. The MESILLA VALLEY RADIO CLUB (hereinafter referred to as "Club") is a tax-exempt organization under the provisions of Section 501 (c)(3) of the Internal Revenue Code.

Section 2. The purposes for which this Club is formed and operated are the following:

- a. To promote interest in amateur radio communications and

experimentation;

b. To provide for dissemination of information among its members concerning scientific advancement and progress in the field of radio communications;

c. To organize and train units of licensed radio amateurs who can provide radio communications as a public service;

d. To foster education in the field of electronic communications to both members of the Club and to the public at large; and

e. To encourage and sponsor experimental activities in radio communications to the end that skills and experience gained in amateur radio will further the application of electronics to the benefit of the public at large.

Section 3. No part of the assets or income to this Club shall be the property of the members or any one of them. The assets shall be devoted exclusively to the purposes herein set forth.

Section 4. To assist in carrying out these purposes, the Club maintains, and intends to maintain, an active affiliation with organizations that support or use amateur radio services.

Section 5. Membership in this Club is open to all persons interested in amateur radio. Full membership is available only to licensed radio amateurs. The club will offer associate membership to non-amateurs who desire to join. Associate members will be non-voting members of the club and cannot hold office. Otherwise, associate members will have all other have all club privileges. To remain a member of the Club, members must comply with the constitution and by-laws and pay their yearly dues.

## **Article II**

### **Officers, Terms, Vacancies and Removal**

Section 1. The officers of this Club shall be a President, a Secretary, and a Treasurer. The officers shall be elected for a term of one year and may run for reelection when their term ends.

Section 2. A board of directors consisting of six directors shall be elected for terms of two years, with three members elected annually. Officers and directors shall be elected by either written or oral ballot of the members. The election will be held at the business meeting in November of each year, and newly elected officers and directors will take office on January 1.

Section 3. Vacancies occurring between elections shall be filled by appointing an acting officer or director to serve until the next regular election. An acting president shall be appointed by the board of directors and other acting officers and directors will be appointed by the president.

Section 4. Officers and directors may be removed by introduction of the motion at a business meeting. At the next business meeting a majority ballot of members present shall be required for removal.

## **Article III**

### **Duties of Officers and Directors**

Section 1. The President shall preside at all business meetings of the Club and shall conduct them according to the rules adopted. He shall enforce due observance of this Constitution and By-Laws, decide all questions of order, sign all official documents adopted by the Club, serve as an ex officio member of all committees and perform all the customary duties pertaining to the office.

Section 2. The Secretary shall record the members present at each

business meeting; maintain the roster of club members including call sign, address, phone number and email address; keep a record of the business meetings and board meetings; submit appropriate applications; carry on both regular and Email correspondence as required; submit communications and minutes of the previous meeting to the newsletter; submit minutes of each business meeting and Club related documentation for inclusion in the Club archive at the end of each calendar year; keep the official copy of the Constitution and By-Laws of the Club; cause all amendments, changes and additions to be made on this official document; and make it available for consultation by members upon request. The secretary shall be responsible for the collection, storage and cataloging of all archive materials passed on to him by various officers specified in this document. The secretary shall assume all the duties of the President in his absence. If there is a motion made at a business meeting to remove the President, the secretary shall assume the duties of the President until the motion is resolved. The secretary shall be responsible for the maintenance of the club calendar. At the end of his term, the Secretary will pass all official documents on to his successor.

Section 3. The Treasurer shall keep an accurate account of all monies received and disbursed; keep an accurate account of the Club's financial assets; and status of the Scholarship Fund in the NMSU Foundation Office. He shall maintain a list of club members who have paid their dues, provide this information to the secretary and assist in maintaining the club roster. He shall provide a monthly report of expenses and income to be published in the Club newsletter. He shall deliver a financial report to the membership at year-end. At the end of his term he shall pass all the records to his successor and to the Club financial records Auditing Committee

Section 4. The Board of Directors shall consist of the officers and six elected directors. The board of directors shall oversee and guide the day-to-day operations of the club in accordance with the members' wishes as agreed at the business meetings. The President shall chair the Board of Directors' meetings. It shall be the responsibility of the Board of Directors to meet before each business meeting to suggest agenda items for the business

meeting; discuss progress of various club projects; prepare a budget for recommendation to the members and to refer concerns of the Club members to the appropriate director for resolution. One director shall be responsible for each of the following areas as defined in the BY LAWS:

Education

Communications

Special Events

Repeaters

Clubhouse

Newsletter

#### **ARTICLE IV**

##### **Ad Hoc Committees**

Ad Hoc committees shall consist of

Auditing Committee,

Nominating Committee and

Scholarship Committee

and other committees as deemed necessary and appointed by the President from time to time.

#### **Article V**

## **Dues**

The Club may levy upon the general membership such dues as provided for in the By Laws which are deemed necessary for the business of the Club within its purposes set forth in Article 1, Section 2. Dues are due in January of each year and are delinquent April 1. An individual who has not paid dues by June 1 will be dropped from the club.

## **Article VI**

### **Budget**

Section 1. In October of each year, each director shall submit to the Board of Directors an annual budget request. The request will include projected needs of the Club for meeting the purposes in Article 1, Section 2. The Board shall review and refine requests and develop a final annual budget. After the board finalizes the budget, it will be presented to the membership for approval at the January business meeting. The board of directors shall have full authority to expend funds identified in the approved budget.

Section 2. Unbudgeted expenditures of less than \$200 per year can be approved by the president. Unbudgeted expenditure of less than \$500 per year can be approved by a majority vote of the Board of Directors. Unbudgeted expenditures greater than \$500 must be approved by a majority vote of the members present at a business meeting.

## **Article VII**

### **Business Meetings and Quorum**

Section 1. Business meetings shall be held monthly. Fifteen percent (15%) of the members shall constitute a quorum for the transaction of all business.



Section 2. Future business meetings may be rescheduled at any monthly business meeting. The club membership shall be provided at least fifteen days notice of the date of the rescheduled business meeting.

## **Article VIII**

### **Member Assistance**

The Club will, within its capabilities, provide advice and assistance to any member requesting it to assure all operations and emissions of member stations conform to FCC regulations and good amateur radio practice.

## **Article IX**

### **Amendments to the Constitution**

All amendments to this Constitution and By-Laws must be submitted and discussed at a business meeting of the Club. They shall be approved at the next business meeting by a majority of members present. The proposed amendments shall be published in the Newsletter prior to the vote.

## **Article X**

### **Disestablishment of the Club and Disposal of Property**

The Club may be dissolved by majority vote of the Board of Directors if liquid assets of the Club (evaluated with due regard to the reasonably anticipated collectables such as dues) become or are anticipated to become insufficient to pay the Club's outstanding and anticipated bills (the condition of which shall be referred to hereinafter as "insolvency"). Before a vote to dissolve may be taken by the Board of Directors, the membership of the Club shall be given notice of an existing or anticipated insolvency and shall be given an opportunity within thirty days to pledge and pay

assessments, contributions or other payments to the Club sufficient in the aggregate to pay all outstanding and anticipated bills of the Club for a period of at least six months.

In the event the Board of Directors votes to dissolve the Club, it shall have authority to sell all assets of the Club (both real and personal). If any funds shall remain after all of the Club's liabilities have been paid, the remaining funds shall be contributed to an amateur radio organization selected by the board of directors. When all club assets have been liquidated, obligations settled and proper authorities (such as the FCC and IRS) notified, the board of directors shall disband.

## **BY LAWS**

### Section 1.

A. Membership. Continuing membership in the Club requires that the member abide by the Constitution and the By Laws and have paid the required dues. A valid amateur radio license shall be required for full membership. Each licensed amateur in a family membership shall have one vote. A member is entitled to all the rights and privileges of the Club. An associate membership will be available for non-licensed individuals and will have all club privileges except for voting.

B. Denial of membership and Expulsion of Members. The board of directors, by a two-thirds majority vote, may elect to deny membership to any individual who has a history of disruptive behavior, verbal or physical assault against club members, intentional jamming, misappropriation of club assets and refusal to abide by the club constitution, by-laws and decisions of the club. Any person denied membership has the right to appeal the board decision to the full membership of the club at a business meeting.

Section 2. Business Meetings. Business meetings shall be held monthly at regular times and days. The day and time for the

business meeting will be determined by the membership and will be announced in the newsletter at least 15 days in advance. The board of directors can cancel a monthly business meeting. The club shall have an annual business meeting in November of each year to elect officers.

Section 3. Social Meetings. Social meetings will be held as desired by the membership. Social meetings are typically breakfast or dinner meetings arranged at a local restaurant and will not constitute a business meeting. The date and time for social functions will be announced in the newsletter at least 15 days in advance.

Section 4. Dues. Dues are levied on an annual basis by the Club. Single membership, family memberships and associate memberships shall be offered. Dues may be prorated for first time members only. Changes in dues will be recommended by the Board of Directors and approved by a majority vote of the members present at a business meeting.

Section 5. Duties of Directors. The elected directors and appointed acting directors shall have the following responsibilities.

a. The Clubhouse Director shall be responsible for the maintenance of the clubhouse and for scheduling work parties and other activities at the clubhouse. He shall formulate policies for operation of the Club station and be responsible for the safekeeping of all Club property and shall serve as custodian of the Club equipment and property. He shall maintain a complete inventory that includes information regarding make, model, serial number, and current location of equipment. He shall maintain the keys for the clubhouse and other associated buildings and maintain a roster of who has keys. The clubhouse director will request assistance from other members as required.

b. The Education Director shall arrange and conduct classes for people who want to receive licenses. Other members of the Club will be called upon to assist with teaching of classes. The education director shall also be responsible for obtaining

speakers and programs for the business meetings.

c. The Repeater Director shall be responsible for operation, maintenance, modifications, installation, frequency coordination, and landlord interfaces for all repeaters operated by the Club.

d. The Communications Director shall be responsible for Field Day and other club contests, for coordinating communication for community events such as races and for coordinating club support to public service organizations, ARES, RACES and etc.

e. The Special Events Director shall plan and implement such activities as the Annual Bean Feed food service, the monthly Saturday breakfast and similar activities. The Director shall also arrange for Club social events such as the annual Christmas Party.

f. The Newsletter Director is the newsletter editor. The Director shall be responsible for obtaining articles, editing, typography and makeup of the newsletter. The Director shall also be responsible for distribution of the monthly newsletter and maintaining an archive of newsletters. The Director is also responsible for the creation and maintenance of the Club WEB site.

Section 6. Ad Hoc Committees. The President may appoint ad hoc committees to be responsible for various Club activities. These committees shall report to the President. The President may remove or add members to each ad hoc committee as necessary. The President shall serve as an ex-officio member of each committee and shall vote only to break ties. Each committee will serve for a specified period of time, after which it will disband. The following ad-hoc committees will be formed as needed.

a. The Auditing Committee shall consist of at least two members who are not officers or directors of the Club. This committee shall audit the financial records of the Club annually or when there is a change in club treasurer. An auditing report will be read at the next business meeting. Upon acceptance, the report and the year-end financial records will be turned over to the treasurer and placed in the archives.

b. The Nominating Committee shall consist of at least three members. The committee will present a selection of at least one candidate for each office to the membership for voting at the November meeting.

c. A Scholarship Fund has been established with New Mexico State University's Foundation. Applications for this annual scholarship are submitted to the Foundation. A Scholarship Committee shall be appointed when there is more than one applicant for the scholarship and shall consist of at least three members. The committee shall select an applicant for award based on the following criteria.

1. Technician or higher-class amateur license.
2. Full-time NMSU student in good standing, pursuing an undergraduate or graduate degree in any major.
3. Sophomore or higher class.
4. Community involvement, contributions to amateur radio, and community service can be considered at the discretion of the committee.

D. Other Ad Hoc Committees will be formed by the president as needed.

Section 7. Order of Business. The order of business shall be arranged at the discretion of the President according to the importance of business to be transacted. A secret ballot may be used to settle any questions when requested by a majority of members present.

I certify that the above Constitution and by-laws for the Mesilla Valley Radio Club are true and accurate. This Constitution and by-laws was voted on and accepted by the membership at the regularly

scheduled business meeting the 5<sup>th</sup> day of February, in the year 2011. I am the elected Secretary for the Mesilla Valley Radio Club,

MS MELANIE JACK, KD5UZF

[Return to Table of Contents](#)

## TECHNICIAN CLASS

AD5FE

The MVRC at the request of David Almaguer the County Emergency Management Supervisor and Steven Lopez Deputy Chief of the NMSU Police Department conducted a Technician License class on January 4 thru January 6 2011. This class was different from our normal class in that it took place during the week, starting Tuesday morning and finishing on Thursday afternoon. The class which was held at the MVRC clubhouse, had 18 students of which 12 were successful in obtaining their Technician License. The class was made up of three students from the Las Cruces Fire Department, two LC-PD officers, three students from the NMSU PD dispatch office, and two emergency managers from Dana Ana County, as well as the NMSU Dep. Chief and his wife. The Emergency Coordinator for NM Department of Homeland Security region 6 was also a student. The class also included four private

citizens with ties to the emergency response field. We also helped the City of Las Cruces chief radio tech get his Technician license and he is already working on upgrading to General. The class was taught by George Kopp (KD5OHA), Bob Bennitt (AD5LJ), Alex Burr (K5XY), Kevin McNelis (K5KMC), and Dave Hassell (WA5DJJ). While the test was administered Thursday afternoon by John Hempling(N5WQ ), Sandy Hempling (KJ5Q ), Dave Anderson (K5DLA ), Joe Ostrowski (KI5FJ ) and Henry Schotzko (AD5FE)."

[Return to Table of Contents](#)

## 2011 BUDGET

WB4AEJ

The 2011 budget is reported here.

# Mesilla Valley Radio Club

## 2011 Budget

## **INCOME 2011**

### **BUDGET 2011**

- Bean Feed \$500.00
- Contributions \$500.00
- Dues 2011 \$2,100.00 (60 paying members)
- Equipment Sales & Raffles \$1,600.00
- Other \$400.00

**TOTAL \$5,700.00**

## **EXPENSES 2011**

### **BUDGET 2011**

- Bean Feed \$400.00
- Breakfast & Drinks \$600.00
- Clubhouse \$500.00
- N5BL Domain Due 09 2016 \$25.00
- Field Day \$100.00
- Insurance \$1,050.00
- Miscellaneous \$100.00
- NM Tax Exempt Fee \$10.00
- P. O. Box Rent \$70.00
- Postage \$75.00
- Property Tax \$1,100.00

- Repeater Maintenance \$465.00
- Electricity \$500.00
- Propane \$450.00
- Water \$175.00

**TOTAL \$5,620.00**

[Return to Table of Contents](#)

## BEAN FEED AD5LJ

The 2011 MVRC Beanfeed is rapidly approaching. As most of you know, we depend on equipment sales at the beanfeed to supply a major portion of the clubs budget for the year. At the current time, we have very few items of equipment to sell. **WE NEED DONATIONS!**

If you have either excess or unwanted amateur equipment, please consider donating it to the MVRC. All donated equipment can be claimed as a tax deduction on your federal tax return. We will take any radio related item you want to donate. However, please consider the following lists of desired and hard to cell equipment. These lists are based on sales at previous beanfeeds. In past years we have ended up sending hard to sell items to the recycling center.

### 1. DESIRED EQUIPMENT:

Modern amateur transceivers, handheld, vehicular and base

Tower sections

Rotators

HF/VHF/UHF ham band antennas

Wire antennas

Antenna parts (insulators, baluns, center insulators, mounts etc)

HF power amplifiers (solid state and tube)

Station accessories

12 VDC power supplies

Power amp tubes

New coax connectors and new coax cable

Modern test equipment



Flat screen monitors

All vintage (tube type) receivers (if clean and complete - need not work)

Boxed receiving tubes

Books (ARRL Handbooks, antenna handbooks, etc)

## 2. EQUIPMENT THAT DOES NOT SELL WELL:

Commercial radio equipment (non ham band)

Components (resistors, capacitors, transformers, ICs and etc)

Non ham band antennas

Old coax cable

Old vacuum tube based test equipment

Vintage transmitters

Satellite TV and Internet equipment

CRT monitors

Any computer more than 5-years old

Computer accessories (printers, UPS, keyboards, mice, etc)

Home audio equipment

Telephones, answering machines, etc

Engineering books and magazines

[Return to Table of Contents](#)

## THE "DOCTOR" AND "OTHER THINGS" ARE IN" N3OL

I am look forward to writing this new series of monthly articles for the N5BL "Local Oscillator" newsletter.

I envision it as an eclectic series of helpful informational references, hardware articles, interesting Ham Radio things of the past, etc..

Drawing inspiration from QST' "Hints and Kinks", "The Doctor is In", and "It seems to Us"; I hope you enjoy it.

By the way, I promise that the technical section will be fully readable by all.

[Return to Table of Contents](#)

## MONTHLY BUSINESS MEETING KD5UZF

Robert Truitt called the meeting to order at 9:32am.

Introductions of all who were present were made.

The QRPSS (slow-transmissions) were talked about and the silly nickname (LC Mafia) that has been given to those using this mode was discussed.

John Hempfling reported about the testing hat was done for the Tech Class. There were several of the class who did not pass the test and were going to re-test.

If you want to test for any license class or upgrade you can call John at 575-644-0344 and he will make arrangements for the test. You can go to QRZ.com for practice tests..John says when you have an 80% score on several of those tests you are ready to call him.

The budget approval motion was made by Richard Johnson and seconded by Charlie Welch. The motion carried.

All three repeaters are up.

George gave us the information about the upcoming races:

- 1.)Feb.6-Superbowl Fun Race,10am- 10-`5people
- 2.)Feb20-Horse Jump, Isaacs Ranch, 5-6people
- 3.)Mar.27-Bataan March,4:30am 24people

A reminder that the Weekly Net is at 6:45 on Wednesday evenings.

The ARES meetings are on the 2<sup>nd</sup> Tuesday in January and March.

More information later.

[Return to Table of Contents](#)

## MONTHLY BOARD MEETING KD5UZF

Robert called the meeting to order at 7 pm

Present were:

Melanie Jack KD5UZF

Cash Olsen KD5SSJ

Robert Truitt KE5OFK

Fred Atkinson WB4AEJ

Terry Angle KF5DNS

George Kopp KD5OHA

Henry Schotzko AD5FE

Vern Vondeeder WV5N

Lou Poli N3OL

Henry reported that things are quiet. We were called in during the cut off of communications in December.

That situation seems to be corrected. We are going to install An antenna at the State Police office.

Cash is working with Bob Bennett, Fred Atkinson and Lou Poli on programs. He is trying to set up a Tech class for Mid-February.

We had several calls and some new people generated by the article in the Sun News. Thank you Fred. He also hopes

To get a General and an Extra class sometime this year. We are going to try to put together a Power Point presentation

To aid in the teaching process for the classes. The classes would be held on a Friday, Saturday, Sunday schedule. We also feel that the cost of the Tech class may have to be increased.

The motion was made by Cash Olsen and seconded by Fred Atkinson to move the Bean-feed to May 1, 2011 in order not to conflict with Easter Sunday. The motion carried.

Breakfast is doing well, but Terry needs some volunteers to help with cleanup. It will only take a few minutes if we have enough helping hands.

The QSO Party will be April 16-17 this year. We won't have a meal but can provide snacks and drinks.

Vern Vondeeder was nominated to be the repeater director by Cash Olsen. The motion was seconded by George Kopp. The motion carried.

The changes to the constitution were discussed. The wording in the section regarding the dissolution of the Club is to be re-written.

The maintenance of the roster of club members is to be maintained by the secretary.

We also discussed the possibility of a need for an Internet Director. Should the position be elected or appointed?

The meeting was adjourned at 8:45pm.

Respectfully submitted,

Melanie Jack, KD5UZF, Secretary

[Return to Table of Contents](#)

UNCLASSIFIED

FOR SALE

Tower

My tower is not a problem to take down, in fact I could take it down by myself if I have too.

I am just looking for a buyer for the entire set up; tower, beam, dipoles, rotator & cable,

low loss feedline-hardline, non conductive guy lines and anchor screws.

One complete package including some spare parts. All I really need is a buyer.

W5UMQ

[Return to Table of Contents](#)

## CLUB INFORMATION

The MVRC Clubhouse is located at the intersection of Wilt and Jefferson in Hacienda Heights. To find the clubhouse, set your destination on your GPS receiver as 32 degrees 22.961 minutes and -106 degrees 41.44 minutes. If you don't own a gps, take the Porter exit on US 70. It is about 5 miles from the I 25 interchange, near the firehouse. Almost immediately south of the south frontage road on the south side of US 70, turn left toward the mountains until you come to Wilt. Turn right. There is a jog in the road, but at 0.35 miles you should come to Jefferson. If you can't see the tower and beam, you shouldn't be driving. The treasurer would be delighted to receive your contribution for landscaping and furnishing.

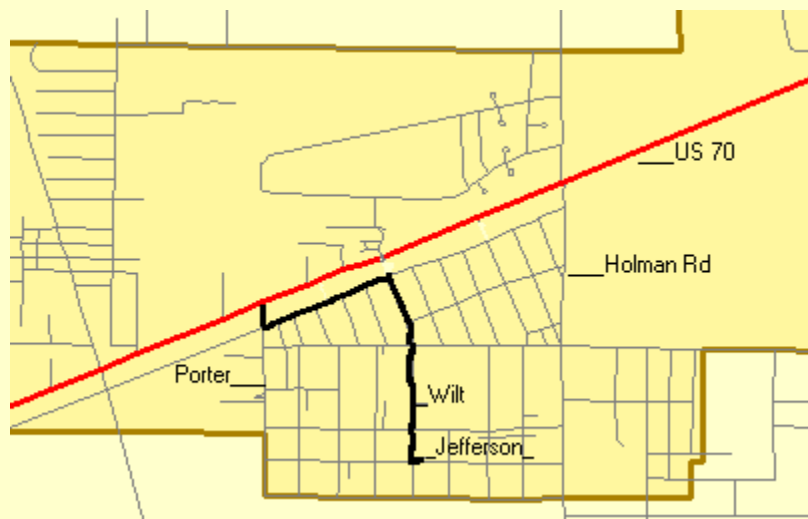

## Officers

Office	Name	Call	Phone	E-Mail
President	Robert Truitt	KE5OFK	649-4173	<a href="mailto:robhtruitt@zianet.com">robhtruitt@zianet.com</a>
Secretary	Melanie Jack	KD5UZF	202-3363	<a href="mailto:thedragon@melaniestonejack.com">thedragon@melaniestonejack.com</a>
Treasurer	Fred Atkinson	WB4AEJ	526-2541	<a href="mailto:fred@wb4aej.com">fred@wb4aej.com</a>
Board Members				
	Terry Angle	KF5DNS	640-9669	<a href="mailto:kf5dns@gmail.com">kf5dns@gmail.com</a>
	Bob Bennett	AD5LJ	382-0148	<a href="mailto:rpbennett1@comcast.net">rpbennett1@comcast.net</a>
	Alex. Burr	K5XY	522-2528	<a href="mailto:k5xy@arrl.net">k5xy@arrl.net</a>
	Cash Olsen	KD5SSJ	382-1917	<a href="mailto:kd5ssj@arrl.net">kd5ssj@arrl.net</a>
	Henry Schotzko	AD5FE	526-1922	<a href="mailto:schotzko@comcast.net">schotzko@comcast.net</a>
	Vern Vondeeder	WV5N	510-909-0069	<a href="mailto:vern@wv5n.com">vern@wv5n.com</a>

The newsletter is always looking for articles and notes of interest to the members of the Mesilla Valley Radio Club. Please send them to Alex. F. Burr, K5XY, Editor, MVRC Local Oscillator, 695 Stone Canyon Drive, Las Cruces, NM 88011. Small personal ads from members will also be published. It would be helpful if submissions would be made in a machine readable form. Windows readable disks are welcome. Files can also be sent to the Internet address [k5xy@arrl.net](mailto:k5xy@arrl.net). The club maintains a web site at <http://www.n5bl.org>

### JOIN THE CLUB

To join the Mesilla Valley Radio Club, renew your membership, or to support the repeaters, please print, cut out, and complete the form below. Send it with dues (\$35 single, \$45 family per year, add \$10 to receive the newsletter by US mail instead of e-mail) to: Treasurer, MVRC, Box 1443, Las Cruces, NM 88004.

MESILLA VALLEY RADIO CLUB CALL SIGN(S) _____ FAMILY _____ _____ LIC CLASS (E, A, G, T, N) _____ ARRL (Y/N) _____ ARRL VE (Y/N) _____ Would you like to be added to the MVRC reflector? _____ NAME _____	
EMAIL _____	
STREET ADDRESS _____ _____	
CITY & ZIP _____ PHONE _____ (OPTIONAL) INTERESTS – Computer __ Contests __ Digital __ Elmer __ Emergency Communications __ Field Day __ Packet __ Programs __ Public Service __ Publicity __ RFI __ Repeater __ Social __ Take License Classes __ Teach License Classes __ Volunteer Examiner __ Other _____ SINGLE \$35 FAMILY \$45	

[Return to home page](#)

[Return to Local Oscillator first page](#)

[Return to N5BL home page](#)