

2010

Local Oscillator

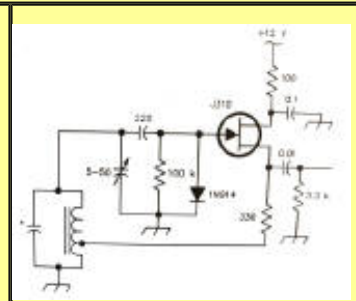

December

Mesilla Valley Radio Club

A [pdf file](#) of this issue is available. It should print fairly easily. If you do not have the free pdf file reader, go to <http://www.adobe.com>

Coming Events

Table of Contents

Date	Event	Time
M - F	6 m FM net 52.540	6:00AM
T, T	Informal Wal-Mart (E)	10:00AM
M, W, F	Informal Wal-Mart (W)	10:00AM
Mon	WTRA Swap net 146.88	8 PM
Wed	Net 146.64	6:45PM
Dec 4	NO Breakfast - Club House	8 AM
Dec 4	NO Business meet	9 AM
Dec 5	NO Builders Group	7 PM
Dec 7	Christmas Dinner - Furr's	6 PM
Dec 8	Board Meeting - Club House	7 PM
Dec 21	NO Builders Group	7PM
Jan 29	Albuquerque Winter Tailgate Swapfest (Albuquerque, NM)	
	for more events see http://www.n5bl.org/calendar	

COMING EVENTS
 TABLE OF CONTENTS
[CONSTITUTION](#)
[TWO RACES](#)
[HAM ANTENNA](#)
[MONTHLY BUSINESS MEETING](#)
[MONTHLY BOARD MEETING](#)
[BACK PAGE](#)



Turkey Trot NCS

A banner image for Southwest Antennas & Accessories. The background shows a close-up of a person's hands working on a complex antenna structure, possibly a parabolic dish or a similar large-scale antenna. The text "Southwest Antennas & Accessories" is overlaid in a bold, white, sans-serif font on the right side of the image.

Southwest Antennas & Accessories

more information at <http://swantenna.com>

The space below is used for acknowledgements and maintaining the site.
Send comments, suggestions, and requests to [Alex. F. Burr](mailto:Alex.F.Burr) or send e-mail to [aburr @ qzxservices.com](mailto:aburr@qzxservices.com).
Technical assistance, net access, design, and maintenance provided by qzxservices.com

THE ARTICLES FOR THIS MONTH

PROPOSED CHANGES TO THE MVRC CONSTITUTION AD5LJ

At the Board of Directors meeting on 10 November 2010, the board reviewed proposed changes to the club constitution and by-laws. The board approved the proposed changes and voted to publish the proposed constitution in the Local Oscillator for review by the membership. The constitution will be discussed at the January 2011 business meeting and voted on.

SUMMARY of CHANGES

The current constitution and by-laws were drafted in the early 1990's when the club had a much larger membership, more of the club members were involved in club activities and we did not have a clubhouse. The original constitution called for the formation of multiple committees, each chaired by a director, to transact all club business and activities. Just about every proposed action had to be approved by the membership. The club's peak membership was 178 in 1995 and is now 76. We no longer have the human resources available to fully comply with the constitution and by-laws. The proposed changes address this issue and clean up some confusing text in the existing constitution.

1. For the last five or so years, it has been increasingly difficult to find candidates for club officers and directors. The job of Vice President has been very difficult to fill. The proposed change eliminates the position of vice president and reassigns his duties to other officers and directors.
2. The board of directors are given the power to appoint an acting officer or director to fill a vacancy that occurs between elections.
3. The board of directors' authority has been expanded to allow them to make minor financial decisions without referring the action to the membership for approval.
4. The duties and responsibilities of the officers and directors have been expanded.
5. The by-laws dealing with membership eligibility have been expanded.

PROPOSED REVISION. Nov 2010

MESILLA VALLEY RADIO CLUB

CONSTITUTION and BY LAWS

Article I

Name, Purpose and Membership

Section 1. The name of this organization shall be the MESILLA VALLEY RADIO CLUB,

a non-profit organization incorporated under the laws of the State of New Mexico for charitable and educational purposes. The MESILLA VALLEY RADIO CLUB (hereinafter referred to as “Club”) is a tax-exempt organization under the provisions of Section 501 (c)(3) of the Internal Revenue Code.

Section 2. The purposes for which this Club is formed and operated are the following:

- a. To promote interest in amateur radio communications and experimentation;**
- b. To provide for dissemination of information among its members concerning scientific advancement and progress in the field of radio communications;**
- c. To organize and train units of licensed radio amateurs who can provide radio communications as a public service;**
- d. To foster education in the field of electronic communications to both members of the Club and to the public at large; and**
- e. To encourage and sponsor experimental activities in radio communications to the end that skills and experience gained in amateur radio will further the application of electronics to the benefit of the public at large.**

Section 3. No part of the assets or income to this Club shall be the property of the members or any one of them. The assets shall be devoted exclusively to the purposes herein set forth.

Section 4. To assist in carrying out these purposes, the Club maintains, and intends to maintain, an active affiliation with organizations that support or use amateur radio services.

Section 5. Membership in this Club is open to all persons interested in amateur radio. Full membership is available only to licensed radio amateurs. The club will offer associate membership to non-amateurs who desire to join. Associate members will be non-voting members of the club. To remain a member of the Club, members must comply with the constitution and by-laws and pay their yearly dues.

Article II

Officers, Terms, Vacancies and Removal

Section 1. The officers of this Club shall be a President, a Secretary, and a Treasurer. The officers shall be elected for a term of one year and may run for reelection when their term ends.

Section 2. A board of directors consisting of six directors shall be elected for terms of two years, with three members elected annually. Officers and directors shall be elected by either written or oral ballot of the members. The election will be held at the business meeting in November of each year, and newly elected officers and directors will take office on January 1.

Section 3. Vacancies occurring between elections shall be filled by appointing an acting officer or director to serve until the next regular election. An acting president shall be appointed

by the board of directors and other acting officers and directors will be appointed by the president.

Section 4. Officers and directors may be removed by introduction of the motion at a business meeting. At the next business meeting a majority ballot of members present shall be required for removal.

Article III

Duties of Officers and Directors

Section 1. The President shall preside at all business meetings of the Club and shall conduct them according to the rules adopted. He shall enforce due observance of this Constitution and By-Laws, decide all questions of order, sign all official documents adopted by the Club, serve as an ex officio member of all committees and perform all the customary duties pertaining to the office.

Section 2. The Secretary shall record the members present at each business meeting; maintain the roster of club members including call sign, address, phone number and email address; keep a record of the business meetings and board meetings; submit appropriate applications; carry on both regular and Email correspondence as required; submit communications and minutes of the previous meeting to the newsletter; submit minutes of each business meeting and Club related documentation for inclusion in the Club archive at the end of each calendar year; keep the official copy of the Constitution and By-Laws of the Club; cause all amendments, changes and additions to be made on this official document; and make it available for consultation by members upon request. The secretary shall be responsible for the collection, storage and cataloging of all archive materials passed on to him by various officers specified in this document. The secretary shall assume all the duties of the President in his absence. If there is a motion made at a business meeting to remove the President, the secretary shall assume the duties of the President until the motion is resolved. The secretary shall be responsible for the maintenance of the club calendar. At the end of his term, the Secretary will pass all official documents on to his successor.

Section 3. The Treasurer shall keep an accurate account of all monies received and disbursed; keep an accurate account of the Club's financial assets; and status of the Scholarship Fund in the NMSU Foundation Office. He shall maintain a list of club members who have paid their dues, provide this information to the secretary and assist in maintaining the club roster. He shall provide a monthly report of expenses and income to be published in the Club newsletter. He shall maintain the MVRC Email Reflector, add new members and delete nonmembers as required. He shall deliver a financial report to the membership at year-end. At the end of his term he shall pass all the records to his successor and to the Club financial records Auditing Committee

Section 4. The Board of Directors shall consist of the officers and six elected directors. The board of directors shall oversee and guide the day-to-day operations of the club

in accordance with the members' wishes as agreed at the business meetings. The President shall chair the Board of Directors' meetings. It shall be the responsibility of the Board of Directors to meet before each business meeting to suggest agenda items for the business meeting; discuss progress of various club projects; prepare a budget for recommendation to the members and to refer concerns of the Club members to the appropriate director for resolution. One director shall be responsible for each of the following areas as defined in the BY LAWS:

**Education
Communications
Special Events
Repeaters
Clubhouse
Newsletter**

ARTICLE IV

Ad Hoc Committees

Ad Hoc committees shall consist of

**Auditing Committee,
Nominating Committee and
Scholarship Committee**

and other committees as deemed necessary and appointed by the President from time to time.

Article V

Dues

The Club may levy upon the general membership such dues as provided for in the By Laws which are deemed necessary for the business of the Club within its purposes set forth in Article 1, Section 2. Dues are due in January of each year and are delinquent April 1. An individual who has not paid dues by June 1 will be dropped from the club.

Article VI

Budget

Section 1. In October of each year, each director shall submit to the Board of Directors an annual budget request. The request will include projected needs of the Club for meeting the purposes in Article 1, Section 2. The Board shall review and refine requests and develop a final annual budget. After the board finalizes the budget, it will be presented to the membership for approval at the January business meeting. The board of directors shall have full authority to expend funds identified in the approved budget.

Section 2. Unbudgeted expenditures of less than \$200 per year can be approved by the president. Unbudgeted expenditure of less than \$500 per year can be approved by a majority vote of the Board of Directors. Unbudgeted expenditures greater than \$500 must be approved by a

majority vote of the members present at a business meeting.

Article VII

Business Meetings and Quorum

Section 1. Business meetings shall be held monthly. Fifteen percent (15%) of the members shall constitute a quorum for the transaction of all business.

Section 2. Future business meetings may be rescheduled at any monthly business meeting. The club membership shall be provided at least fifteen days notice of the date of the rescheduled business meeting.

Article VIII

Member Assistance

The Club will, within its capabilities, provide advice and assistance to any member requesting it to assure all operations and emissions of member stations conform to FCC regulations and good amateur radio practice.

Article IX

Amendments to the Constitution

All amendments to this Constitution and By-Laws must be submitted and discussed at a business meeting of the Club. They shall be approved at the next business meeting by a majority of members present. The proposed amendments shall be published in the Newsletter prior to the vote.

Article X

Disestablishment of the Club and Disposal of Property

The Club may be dissolved by majority vote of the Board of Directors if liquid assets of the Club (evaluated with due regard to the reasonably anticipated collectables such as dues) become or are anticipated to become insufficient to pay the Club's outstanding and anticipated bills (the condition of which shall be referred to hereinafter as "insolvency"). Before a vote to dissolve may be taken by the Board of Directors, the membership of the Club shall be given notice of an existing or anticipated insolvency and shall be given an opportunity within thirty days to pledge and pay assessments, contributions or other payments to the Club sufficient in the aggregate to pay all outstanding and anticipated bills of the Club for a period of at least six months.

In the event the Board of Directors votes to dissolve the Club, it shall have authority to sell all assets of the Club (both real and personal). If any funds shall remain after all of the Club's liabilities have been paid, the remaining funds shall be contributed to the NMSU Scholarship Fund and the Board of Directors shall request that the NMSU Foundation thereafter administer the funds. When all club assets have been liquidated, obligations

settled and proper authorities (such as the FCC and IRS) notified, the board of directors shall disband.

BY LAWS

Section 1.

A. Membership. Continuing membership in the Club requires that the member abide by the Constitution and the By Laws and have paid the required dues. A valid amateur radio license shall be required for full membership. Each licensed amateur in a family membership shall have one vote. A member is entitled to all the rights and privileges of the Club. An associate membership will be available for non-licensed individuals and will have all club privileges except for voting.

B. Denial of membership and Expulsion of Members. The board of directors, by a two-thirds majority vote, may elect to deny membership to any individual who has a history of disruptive behavior, verbal or physical assault against club members, intentional jamming, misappropriation of club assets or refuses to abide by the club constitution, by-laws and decisions of the club. Any person denied membership has the right to appeal the board decision to the full membership of the club at a business meeting.

Section 2. Business Meetings. Business meetings shall be held monthly at regular times and days. The day and time for the business meeting will be determined by the membership and will be announced in the newsletter at least 15 days in advance. The board of directors can cancel a monthly business meeting. The club shall have an annual business meeting in November of each year to elect officers.

Section 3. Social Meetings. Social meetings will be held as desired by the membership. Social meetings are typically breakfast or dinner meetings arranged at a local restaurant and will not constitute a business meeting. The date and time for social functions will be announced in the newsletter at least 15 days in advance.

Section 4. Dues. Dues are levied on an annual basis by the Club. Single membership, family memberships and associate memberships shall be offered. Dues may be prorated for first time members only. Changes in dues will be recommended by the Board of Directors and approved by a majority vote of the members present at a business meeting.

Section 5. Duties of Directors. The elected directors and appointed acting directors shall have the following responsibilities.

a. The Clubhouse Director shall be responsible for the maintenance of the clubhouse and for scheduling work parties and other activities at the clubhouse. He shall formulate policies for operation of the Club station and be responsible for the safekeeping of all Club property and shall serve as custodian of the Club

equipment and property. He shall maintain a complete inventory that includes information regarding make, model, serial number, and current location of equipment. He shall maintain the keys for the clubhouse and other associated buildings and maintain a roster of who has keys. The clubhouse director will request assistance from other members as required.

b. The Education Director shall arrange and conduct classes for people who want to receive licenses. Other members of the Club will be called upon to assist with teaching of classes. The education director shall also be responsible for obtaining speakers and programs for the business meetings.

c. The Repeater Director shall be responsible for operation, maintenance, modifications, installation, frequency coordination, and landlord interfaces for all repeaters operated by the Club.

d. The Communications Director shall be responsible for Field Day and other club contests, for coordinating communication for community events such as races and for coordinating club support to public service organizations, ARES, RACES and etc.

e. The Special Events Director shall plan and implement such activities as the Annual Bean Feed food service, the monthly Saturday breakfast and similar activities. The Director shall also arrange for Club social events such as the annual Christmas Party.

f. The Newsletter Director is the newsletter editor. The Director shall be responsible for obtaining articles, editing, typography and makeup of the newsletter. The Director shall also be responsible for distribution of the monthly newsletter and maintaining an archive of newsletters. The Director is also responsible for the creation and maintenance of the Club WEB site.

Section 6. Ad Hoc Committees. The President may appoint ad hoc committees to be responsible for various Club activities. These committees shall report to the President. The President may remove or add members to each ad hoc committee as necessary. The President shall serve as an ex-officio member of each committee and shall vote only to break ties. Each committee will serve for a specified period of time, after which it will disband. The following ad-hoc committees will be formed as needed.

a. The Auditing Committee shall consist of at least two members who are not officers or directors of the Club. This committee shall audit the financial records of the Club annually or when there is a change in club treasurer. An auditing report will be read at the next business meeting. Upon acceptance, the report and the year-end financial records will be turned over to the treasurer and placed in the archives.

b. The Nominating Committee shall consist of at least three members. The committee will present a selection of at least one candidate for each office to the membership for voting at the November meeting.

c. A Scholarship Fund has been established with New Mexico State University's Foundation. Applications for this annual scholarship are submitted to the Foundation. A Scholarship Committee shall be appointed when there is more than one applicant for the scholarship and shall consist of at least three members. The committee shall select an applicant for award based on the following criteria.

- 1. Technician or higher-class amateur license.**
- 2. Full-time NMSU student in good standing, pursuing an undergraduate or graduate degree in any major.**
- 3. Sophomore or higher class.**
- 4. Community involvement, contributions to amateur radio, and community service can be considered at the discretion of the committee.**

D. Other Ad Hoc Committees will be formed by the president as needed.

Section 7. Order of Business. The order of business shall be arranged at the discretion of the President according to the importance of business to be transacted. A secret ballot may be used to settle any questions when requested by a majority of members present.

I certify that the above Constitution and by-laws for the Mesilla Valley Radio Club are true and accurate. This Constitution and by-laws was voted on and accepted by the membership at the regularly scheduled business meeting the ----day of-----, in the year ----. I am the elected Secretary for the Mesilla Valley Radio Club,

[Return to Table of Contents](#)

TWO RACES
KD5OHA

The first race was the Las Cruces Horseman's Associations Las Cruces Horse Trials. It was a sunny but windy day on Sunday November 21. As a group of amateur radio operators. arrived at Isaack's Ranch. north and east of the city off of highway 70. We were there to help with the Las Cruces Horseman's Associations Las Cruces Horse Trials horse jump competition. We arrived at 07:30 for instructions as to what we would be doing and what jump we would be assigned to. The day started with over 70 riders in different age groups and categories. Some of the riders had 18 jumps to complete. By afternoon the wind had really picked up. But we did not see any horses blow away so the competition continued. The last rider finished at around 14:45. Many thanks to George, KD5OHA; John, WK5C; Perry, KC7VHS; Dave, K5DLA; Vern, WV5N; and Kevin, K5KMC for a job well done.

The second race was the Turkey Trot. November 25, Thanksgiving Day, started out a little on the cool side, but it warmed up nicely for the 1 mile and 5K run walk for the Mesilla Valley Track Clubs Turkey Trot Race. There was 230 people in the event. The 1 mile 2 lap race around Buena Vida Park started at 8 A.M. and was finished by 8:20 A.M.

At 08:30 the 5K run walk started. The first 5K runner crossed the finish line in 17 minutes and 15 seconds. In the 5K walk Alex Burr came in first in 38 minutes and 32 seconds. Charlotte Johnson came in 2nd in her division at 47 minutes and 44 seconds.

Many thanks to George, KD5OHA; Chris, KD5SSI; Dave, K5DLA; Henry, AD5FE; Vern ,WV5N; Cash, KD5SSJ; Kevin, K5KMC; and Richard, KC5EVR. They all did an excellent job of communicating the location of the runners and walkers

[Return to Table of Contents](#)

HAM ANTENNA FOR THE WEATHER STATION AD5FE

For those of you who are not aware of it the National Weather Service office down at Santa Teresa has a ham radio station that has recently been activated. This station was brought about by a joint effort of the El Paso and Dona Ana ARES Teams. The NWS bought the radio, a Yaesu FT857, and a power supply to power it.

It fell to the local hams to get it installed and put up antennas for it.

As it turns out that was easier then we first thought, as they already had two antennas on a tower that would support both VHF and UHF operation, which left only HF to be dealt with.

The first step for the joint ARES team was the testing and repairing, as needed, of the two already installed antennas, which lead to the repair of one and the replacement of the other, giving us a dual-band vertical on the top of the tower and a disc-cone about half way up the tower. We also tested the co-ax lead-in and checked to see what was there in preparation of the install of the proposed HF antenna, which was to be a horizontal loop tuned for 75 meters.

We also programmed the FT-857 with local VHF and UHF repeaters that could be used in the event of bad weather. The plans were then laid for the next step which was the install of the 75 meter loop. This meant getting permission from the NWS to attach to structures on their grounds, which it seems took longer then getting the antenna parts together. The joint team met out at the Weather Office on Nov. 4th and completed the loop antenna install, although the loop could use some fine tuning, with the help of an antenna tuner. They now have HF capability.

I would like to thank all those who took part in, or donated material for, this project, the Hams from El Paso, Warren Beadle (KE5APX), Ed Wood (KD5MFS),

Artis Wright (KD5KFY) and Lew Maxwell (KB5HPT), and the ones from here in Las Cruces, Dave Anderson (K5DLA), Joe Ostrowski (KI5FJ), Kevin McNelis (K5KMC), for their efforts that gave us a great tool that just might help save lives in the event of a bad storm. Lest I forget, the Santa Teresa Weather Station uses the call WX5ELP.

The station has already been put to use, as it was activated on 10/20/2010 for the bad weather over by Alamogordo, that proved that we could contact the needed area, but also showed that we needed to come up with a plan as to how we would activate if needed. At this time the ARES DEC's and EC's of the served area are in the process of writing an activation plan for us to use, so we all know what to do and when.

[Return to Table of Contents](#)

MONTHLY BUSINESS MEETING KD5UZF

Cash Olsen gave a presentation on Solar Systems. It was a very good look at alternative energy and the positive and negative aspects of being on or off the grid.

At 10:00am Vern called the meeting to order.

Rob Truitt, KC5OFK agreed to be president. He was nominated by Cash Olsen and seconded by Dave Anderson. The motion carried.

Melanie Jack, KD5UZF agreed to be Secretary/Vice President. She was nominated by Bob Bennett and seconded by Joe Ostrosky. The motion carried.

Cash Olsen, KD5SSJ agreed to be the Education Chairman. He was nominated by Dave Anderson and seconded by Henry Schotzko. The motion carried.

Fred Atkinson, WB4AEJ agreed to be Treasurer. He was nominated by Dave Anderson and seconded by Bob Bennett. The motion carried.

No other business was conducted but we were reminded that the December meeting would be held at Furr's Cafeteria on December 7, 2010 at 6:00 pm.

The meeting adjourned to 11:00am

[Return to Table of Contents](#)

MONTHLY BOARD MEETING KD5UZF

Board Meeting

11-10-10 Board Meeting

Henry Schotzko AD5FE
George Kopp KD5OHA
Bob Bennett AD5LJ
Fred Atkinson WB4AEJ
Cash Olsen KD5SSJ
Melanie Jack KD5UZF

7:05 meeting called to order

A budget meeting has been called for December 8, at 7pm

Bob Bennett is working on by-law revisions.

Cash Olsen moved to approve and Henry Schotzko seconded.

Bob has installed a latch for the back screen and has the photo cell for the light pole to be installed.

Fred will prepare a draft budget for the 12-8-10 meeting.

Vern will order books and videos for the January Tech class. Henry has 15 students. The cost of the class is \$45. The book is \$25 and the class is to be pre-paid and you keep the book and get a \$20 refund if you can't make the class. The maximum for the class is 20 students. here at the clubhouse. The dates are Jan. 4, 9am-5pm Tuesday, Jan. 5, 12pm-5pm Wednesday, Jan. 6, 9am-5pm, Thursday.
Cash will do something for lunch for the classes.

The meeting adjourned to 8:30pm

[Return to Table of Contents](#)

UNCLASSIFIED

WANTED

Wall mount power supply.: 5V 1A Medium sized round center + power connector.

Alex Burr, K5XY 522-2528 or k5xy@arrl.net

[Return to Table of Contents](#)

CLUB INFORMATION

The MVRC Clubhouse is located at the intersection of Wilt and Jefferson in Hacienda Heights. To find the clubhouse, set your destination on your GPS receiver as 32 degrees 22.961 minutes and -106 degrees 41.44 minutes. If you don't own a gps, take the Porter exit on US 70. It is about 5 miles from the I 25 interchange, near the firehouse. Almost immediately south of the south frontage road on the south side of US 70, turn left toward the mountains until you come to Wilt. Turn right. There is a jog in the road, but at 0.35 miles you should come to Jefferson. If you can't see the tower and beam, you shouldn't be driving. The treasurer would be delighted to receive your contribution for landscaping and furnishing.

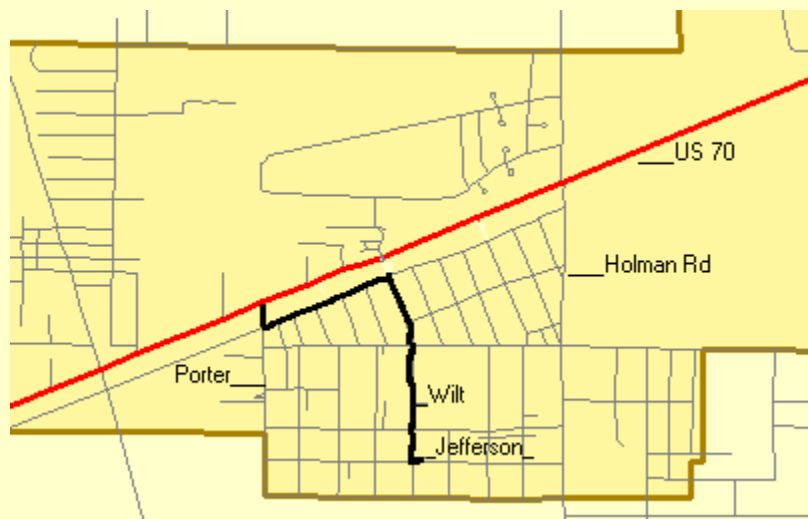

Officers

Office	Name	Call	Phone	e-mail
President	Vern Vondeeder	WV5N	510-909-0069	vern@wv5n.com
Vice-President	Cash Olsen	KD5SSJ	382-1917	kd5ssj@arrl.net
Secretary	Melanie Jack	KD5UZF	202-3363	
Treasurer	Fred Atkinson	WB4AEJ		fred@wb4aej.com
Board Members	Alex. Burr	K5XY	522-2528	k5xy@arrl.net
	Bob Bennett	AD5LJ	382-0148	rbpennett1@comcast.net
	Henry Schotzko	AD5FE		schotzko@comcast.net
	Terry Angle	KF5DNS	640-9669	kf5dns@gmail.com
	Robert Truitt	KE5OFK	649-4173	robtruitt@zianet.com
	Evan Salazar	KE5ZRZ		

The newsletter is always looking for articles and notes of interest to the members of the Mesilla Valley Radio Club. Please send them to Alex. F. Burr, K5XY, Editor, MVRC Local Oscillator, 695 Stone Canyon Drive, Las Cruces, NM 88011. Small personal ads from members will also be published. It would be helpful if submissions would be made in a machine readable form. Windows readable disks are welcome. Files can also be sent to the Internet address k5xy@arrl.net. The club maintains a web site at <http://www.n5bl.org>

JOIN THE CLUB

To join the Mesilla Valley Radio Club, renew your membership, or to support the repeaters, please print, cut out, and complete the form below. Send it with dues (\$35 single, \$45 family per year, add \$10 to receive the newsletter by US mail instead of e-mail) to: Treasurer, MVRC, Box 1443, Las Cruces, NM 88004.

MESILLA VALLEY RADIO CLUB CALL SIGN(S) _____ FAMILY _____ _____ LIC CLASS (E, A, G, T, N) _____ ARRL (Y/N) _____ ARRL VE (Y/N) _____ Would you like to be added to the MVRC reflector? _____ NAME _____	
EMAIL _____	
STREET ADDRESS _____ _____	
CITY & ZIP _____ PHONE _____ (OPTIONAL) INTERESTS – Computer __ Contests __ Digital __ Elmer __ Emergency Communications __ Field Day __ Packet __ Programs __ Public Service __ Publicity __ RFI __ Repeater __ Social __ Take License Classes __ Teach License Classes __ Volunteer Examiner __ Other _____	
SINGLE \$35 FAMILY \$45	

[Return to home page](#)

[Return to Local Oscillator first page](#)

[Return to N5BL home page](#)