

Local Oscillator

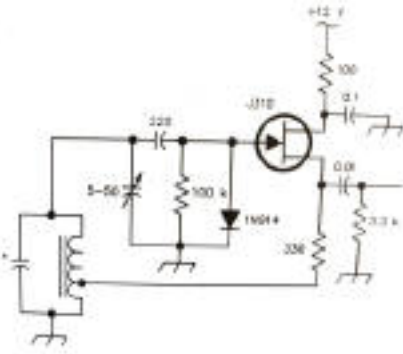

2004

Mesilla Valley Radio Club

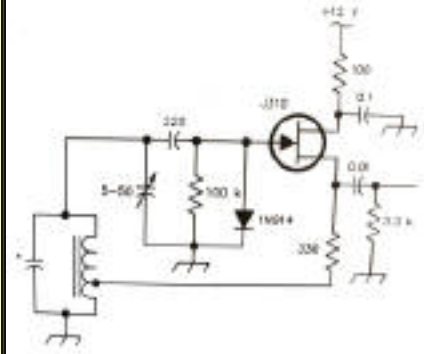

April

A [pdf file](#) of this issue is available. It should print fairly easily. If you do not have the free pdf file reader, go to <http://www.adobe.com>

Events

Table of Contents

Date	Event	Time
M - F	6 m FM net 52.540	6:00AM
M - F	round-table 52.525	8:00PM
T, T	Breakfast Wal-Mart (E)	10:00AM
M, W, F	Informal - Munson Center	10:00AM
Mon	WTRA Swap net 146.88	8 PM
Wed	Net 146.64	6:45PM
Apr 3	Breakfast Club House	8:00AM
Apr 3	Business Meet Club House	9:15AM
Apr 12	Social Meeting New China Buffet	6:00PM
Apr 14	1st Wed after 2nd Mon Directors at clubhouse	7:00PM
Apr 03	Run Old Mesilla	AM
Apr 16-18	General Class Club House	
Apr 18	Triathlon	AM
Apr 25	Bean Feed Club House	7:00AM
Apr 25	Elmer Sessions	

EVENTS

[PRESIDENT'S CORNER](#)

[MIG-17 SEARCH at T or C](#)

[BREAKFAST](#)

[BEANFEED](#)

[A DIFFERENT BUILDER'S GROUP](#)

[UNCLASSIFIED ADS](#)

[CLUB INFORMATION](#)

May 1,2	Extra Class	8:00AM
May 8,9	Club House	
	See Classes for details	



N5XRP Buying at El Paso Hamfest

The space below is used for acknowledgements and maintaining the site.

Send comments, suggestions, and requests to [Alex. F. Burr](mailto:aburr@qzxservices.com) or send e-mail to [aburr @ qzxservices.com](mailto:aburr@qzxservices.com).

Technical assistance, net access, design, and maintenance provided by qzxservices.com

THE ARTICLES FOR THIS MONTH

PRESIDENT'S CORNER

KD4SSJ

The search for the crashed MIG-17 near T or C points out the value of Amateur Radio. (Some of our club members were there helping with communications.) Paul Harvey also highlighted Amateur Radio in a recent broadcast where he told about Amateurs who helped during a natural disaster and many more who stand ready to help whenever needed. We do have a lot of fun in our hobby, but we have a valuable resource that is hard to duplicate. In my EMT training we learned that some departments were considering the use of cell phones by emergency personnel, but that the cell system is liable to being swamped and practically unusable during a disaster, just when you need it the most. This is where Amateurs come in and quietly do what we do best -- communicate over long distances when nobody else can. Thanks to all our members who help in emergency preparedness and in actual emergencies. Contact Jim (WA2NIJ) and Marnie (KA2FVO) Leverett to learn how to get involved.

[Return to Table of Contents](#)

MIG-17 SEARCH at T or C

WA2NIJ

As you may know from reading the papers, a MIG-17 aircraft fell off the radar the morning of Thursday, March 25. The pilot was flying from Roswell to Phoenix. He had declared an in-flight emergency. He reported having trouble balancing his fuel tanks. The last known coordinates were near Truth or Consequences.

I received a call from the Search and Rescue Incident Commander Thursday requesting communications support. This is the first time MVRC has been called out other than by MVSAR. Marnie and I drove up to the T or C airport Friday morning. Friday was aerial search only. MVSAR and other groundpounders were on standby. We communicated with the State Police helicopter, N606SP on the state SAR frequency, 155.160 simplex. We also talked to the Civil Air Patrol planes on their repeater, using a borrowed transceiver. We also had the use of an aviation radio on 123.1 MHz, but there was nothing on that frequency.

Our incident base was having trouble communicating by telephone with the CAP mission base in Alamogordo. Jim O'Leary, N7DRB drove out to the CAP hangar to establish ham radio contact.

John Hempfling, N5WQ and Sandy, KJ5Q, relieved us in the afternoon. John

Beakley, WK5C arrived with his trailer in the evening. Charlie Mabry, K9AQH arrived for Saturday duty. Next day, Saturday, the groundpounders, ATVers and horse people arrived. By 2:45 P. M. the crash site had been found. The Albuquerque radar track showed that the plane had broken up into more than one piece. The NMSF helicopter took the family out to view the crash site. As was reported in the newspapers, MIG-17's do not have ejection seats.

Steve Friis, WM5Z and John Beakley did base communication from Las Cruces. Jack Lemons, N5PK and the Hempflings were on standby to serve on Sunday but did not have to come.

[Return to Table of Contents](#)

BREAKFAST

KD5SSJ

Join us for breakfast at 8:00 am on Saturday, April 3. New members Leslie and Mike Morrell have volunteered to assist with breakfast.

[Return to Table of Contents](#)

BEAN FEED

KD5SSJ

It's Spring and the weather is great. That should give you good reason to be working on the shack. Spring also is associated with cleaning, so while your in the shack start looking at the stuff that no longer serves you. Then make a pile and bring it to the club house as a donation or bring on Sunday, April 25 for tailgating. We'll start the tailgate at 8:00 am (but unofficially whenever the first two of you arrive). We've added three racks of equipment from a TVRO Satellite Earth Station.

Lunch will be served at noon, the main fare is chile with beans and coleslaw.

I need volunteers to assist with setting up for the Beenfeed, please contact me to tell how you would like to help.

[Return to Table of Contents](#)

A DIFFERENT BUILDER'S GROUP

K5DI

In past years we have had as part of the Mesilla Valley Radio Club MVRC a Builders Group. This has been a lot of fun and many members have

built various electronic devices. This new Group will be formed to do kit building, and you will end up with a nice looking small radio that works!

The radio is a QRP radio, that is, it transmits with 5 or less watts. It is a CW only radio. This means you need to get your code speed up to a good speed. What can you do with a QRP radio? Last evening I talked to Dan in Oregon and Al in New York. My antenna is a 40 meter ground plane. You can hook your finished kit to a random wire and work with others in town who have done the same thing.

The source for the least expensive kit called the SW+40 is at:

<http://www.smallwonderlabs.com/>

and this kit costs \$55.00. A nice cabinet is \$35.00 for a total cost of \$90.00.

The source of NC40a kits is at:

<http://www.fix.net/~jparker/wilderness/nc40a.htm>

and this is for the nc40a radio which I recommend from a cost point of view. You can get this kit complete with the case for \$129 plus \$6 shipping for a total of \$135.00. There is a keyer kit (LC1) that is nice and it costs \$45 plus \$4 shipping for \$49.00.

The source for the Wilderness Sierra kits is at:

<http://www.fix.net/~jparker/wilderness/sierra.htm>

and this is the radio I recommend if you can afford it. To equal the NC40a it costs \$245.00. With 6 bands 80 through 10 meters it's \$369.00. This is a real quality radio which can have all bands if you can afford it.

You can build any of these kits in the MVRC Kit Builders Club. We will meet twice a month. Each member will buy their own kit. Most of the building you will do at home. At the meeting I and other people who have built kits will help you with ANY problem. I have the papers used in the Elmer 101 Class which used the SW+40 kit as the model, and teaches you about basic electronics and the parts of the radio that make it work well.

If your interested in this Group please call Karl Larsen at 524-3303 so we can get started. The exact dates of the Classes will be announced. We will meet at the Clubhouse.

[Return to Table of Contents](#)

UNCLASSIFIED ADS

WANTED: New Mexico ham radio callsign license plates for my collection. Will buy or trade. 505-382-7804, K5ZI@arrl.net, Bill Johnston, P.O. Box 640, Organ, NM 88052-0640.

[Return to Table of Contents](#)

CLUB INFORMATION

The MVRC Clubhouse is located at the intersection of Wilt and Jefferson in Hacienda Heights. The treasurer would be delighted to receive your contribution for landscaping and furnishing. To find the clubhouse, set your destination on your GPS receiver as 32 degrees 22.961 minutes and -106 degrees 41.44 minutes. If you don't own a gps, drive out North Main towards Alamogordo. At about 5 miles from the I 25 interchange, near the firehouse, exit at Porter. Almost immediately turn left and continue toward the mountains until you come to Wilt. Turn right. There is a jog in the road, but at 0.35 miles you should come to Jefferson. If you can't see the tower and beam, you shouldn't be driving.



Officers

Office	Name	Call	Phone	e-mail
President	Tim Linn	KD5SSF	521-0486	kd5ssf@arrl.net
Vice-President	Bob Deal	KD5PPP		bob-verna@zianet.com
Secretary	Carleton Talbot	KC5MRM	(915)877-3538	kc5mrm@zianet.com
Treasurer	Charlie Welch	W5TLU	524-3412	cwwelch@usa.net
Board Members	Alex. Burr	K5XY	522-2528	k5xy@arrl.net
	Bob Bennett	AD5LJ	382-0148	rbennett@zianet.com
	Karl Larsen	K5DI	524-3303	k5di@zianet.com
	Cash Olsen	KD5SSJ	382-1917	casholsen@zianet.com
	Joe San Filippo	WZ5R	521-7574	sanfilippo@zianet.com
	Brad Sacca	KC5SKE	382-4380	sheikyerbouty@uswest.net

The newsletter is always looking for articles and notes of interest to the members of the Mesilla Valley Radio Club. Please send them to Alex. F. Burr, K5XY, Editor, MVRC Local Oscillator, 695 Stone Canyon Drive, Las Cruces, NM 88011. Small personal ads from members will also be published. It would be helpful if submissions would be made in a machine readable form. Windows readable disks are welcome. Files can also be sent to the Internet address aburr@aol.com. The club maintains a web site at <http://www.zianet.com/mvrc>.

JOIN THE CLUB

To join the Mesilla Valley Radio Club, renew your membership, or to support the repeaters, please print, cut out, and complete the form below. Send it with dues (\$25 single, \$35 family per year) to: Treasurer, MVRC, Box 1443, Las Cruces, NM 88004.

Name	
Box or street address	
City	
State	
Zip	
Call	
Class of license	
Phone	
e-mail	
ARRL Member?	

[Return to home page](#)